

VEGA XL
COD: 67792-LBN

Use:
inside, led
Installation:
Track mounted
Fixing system:
Electrical adaptor for track mounting
Body/structure:
body components made ??of extruded aluminum and die-cast aluminum
optical assembly
Coating:
Epoxy powder coating for inside use
Colour:
Grey
Optic/reflector:
Metacrylate LED lens - Adjustable optic
Control gear:
Integrated LED diodes ballast, stabilized output current 700mA dc

Voltage: 220-240V 50/60Hz
Beam angle: Simmetric flood beam 30 Degrees
Insulation class: Insulation class 1
Weight: 2,400 kg
IP rating: 40
Glow wire: [850 °C]
Lamp included: Yes
Kind of led: Power LED
Lamp wattage: 60 W
Lamp luminous flux: 2600 lm
Colour temperature: 4000K
CRI: 80

Review board: 02-09-2014

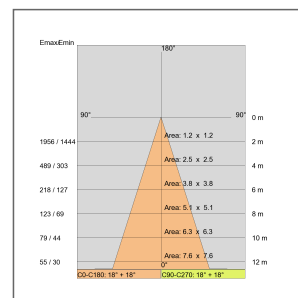
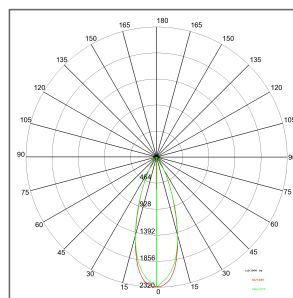
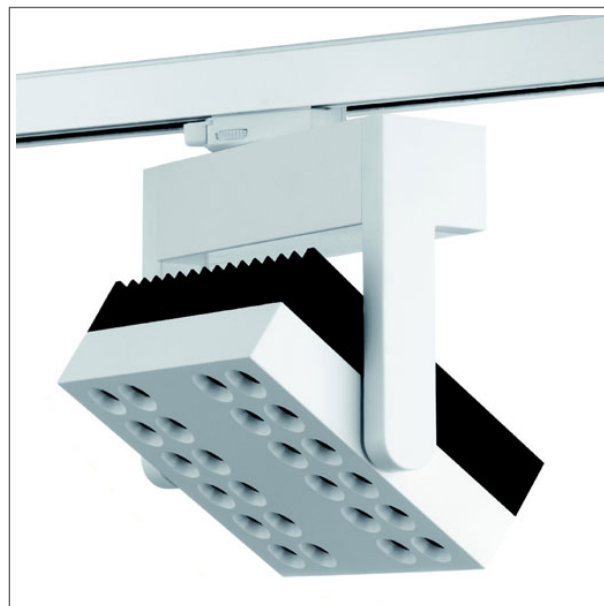

Lamp: 1 x LED +/- 60 W 2600 lm



IP 40 A+

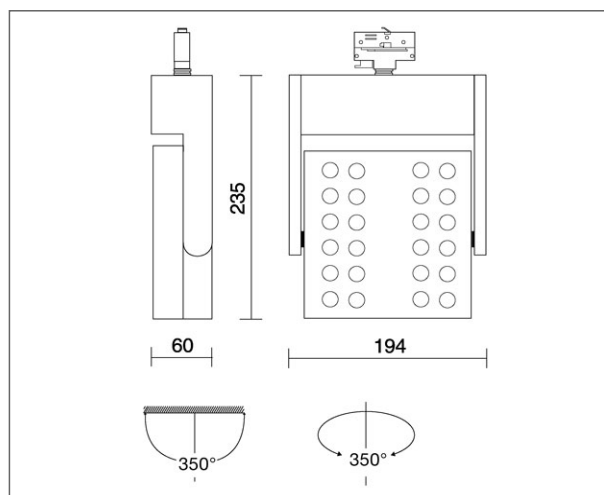

VEGA XL
COD: 67792-LBN

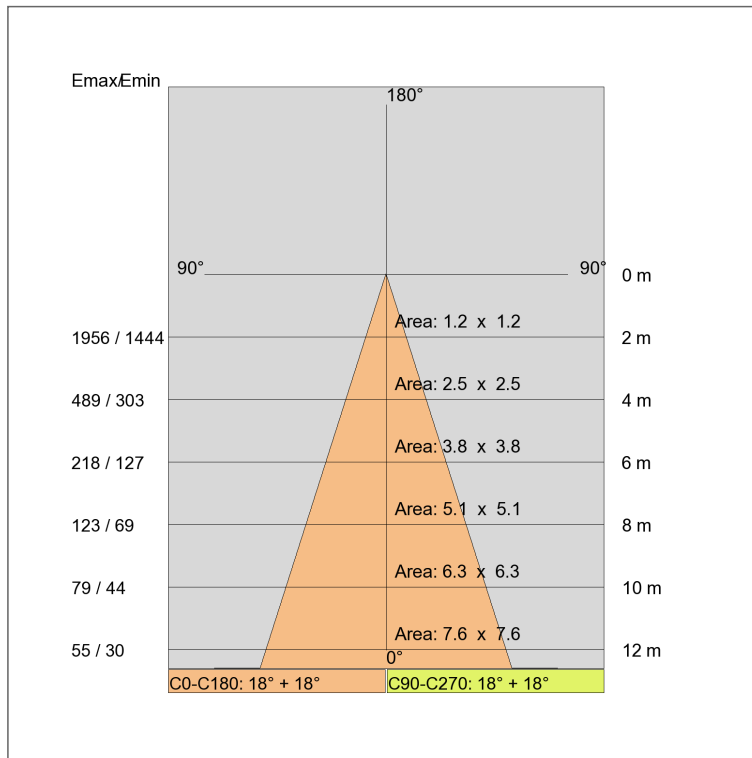
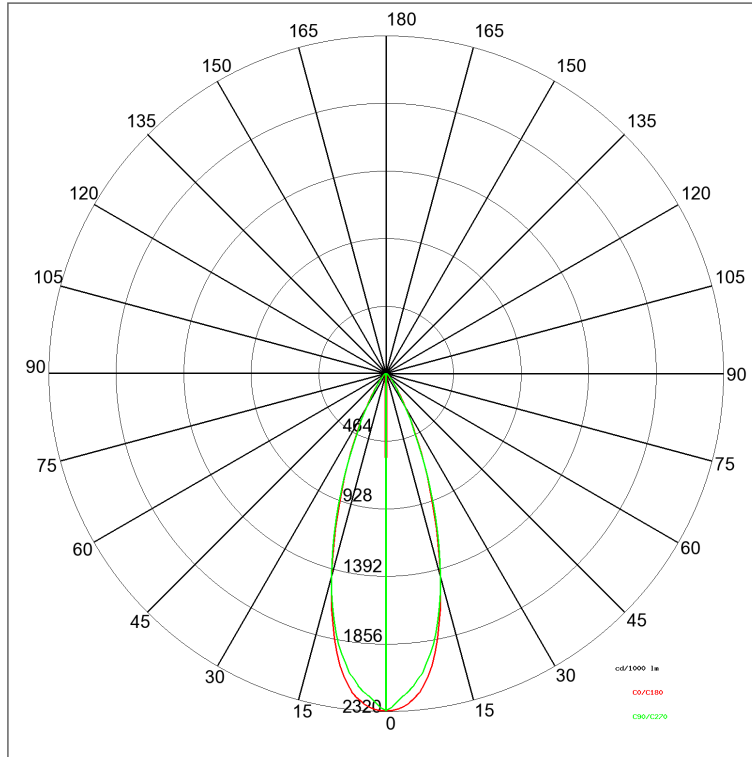

VEGA XL
COD: 67792-LBN

